

ELEVATION  
SCALE 3/4"=1'-0"

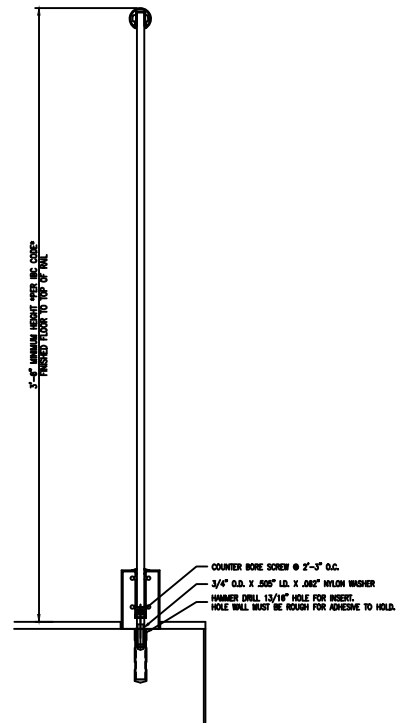

SECTION  
SCALE 3/4"=1'-0"

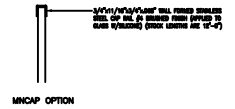
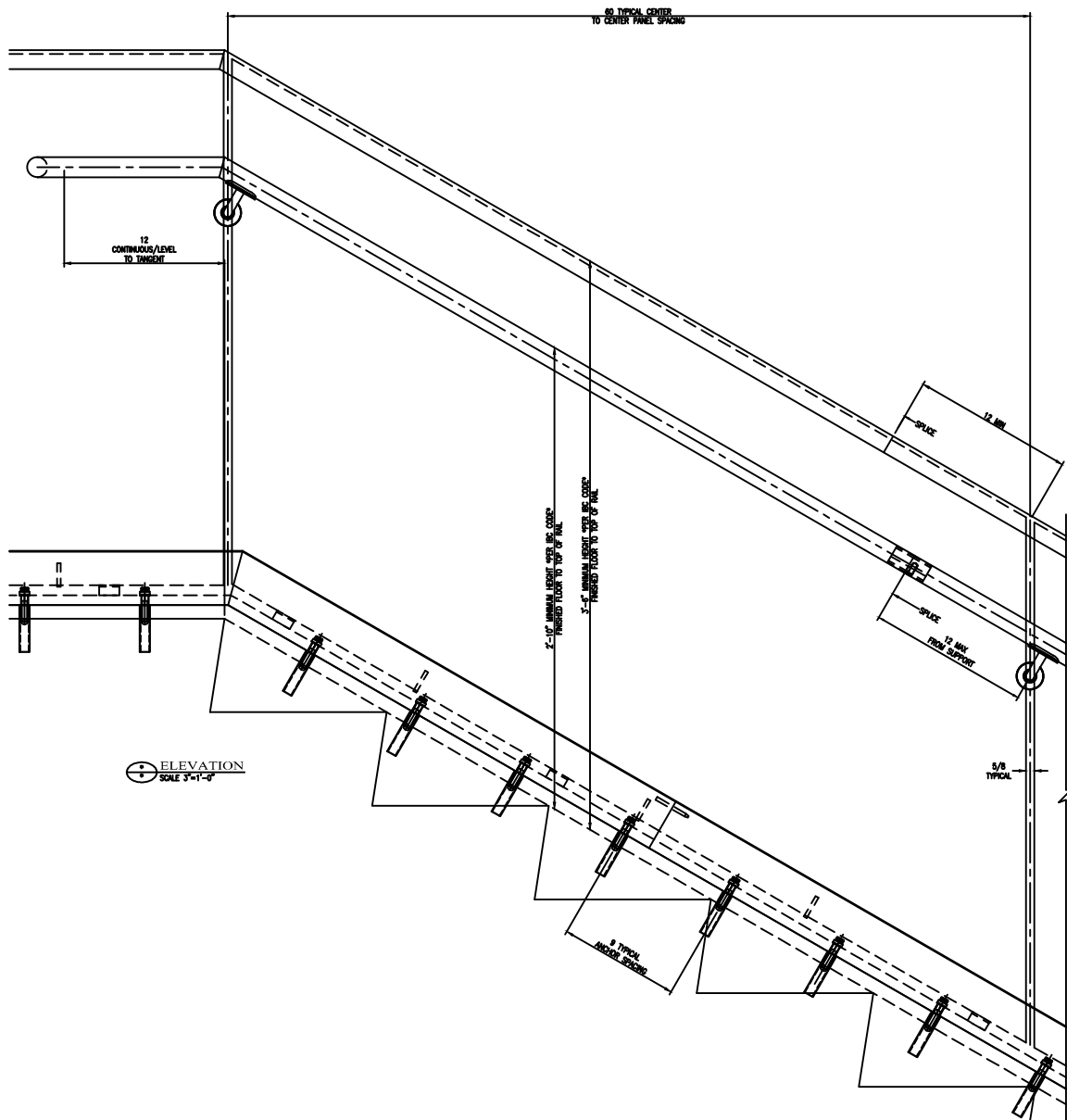

ELEVATION  
SCALE 3/4"=1'-0"

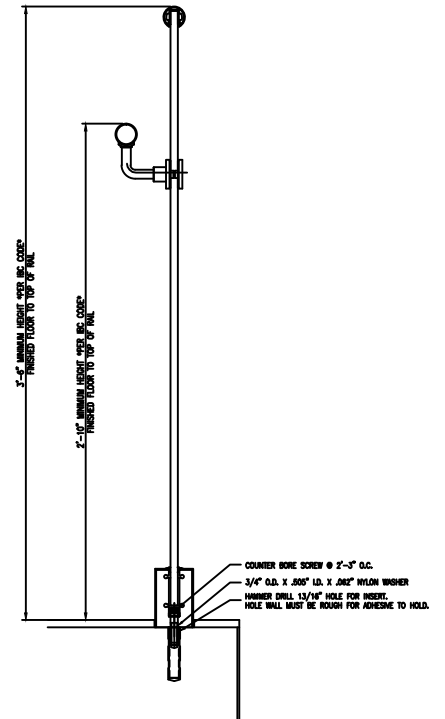

SECTION  
SCALE 3/4"=1'-0"

**LIVERS  
BRONZE**  
401 East 7th Street, Warren, CT 06495  
Phone: 860-266-0262 / Fax: 860-266-0264  
www.liversbronze.com  
info@liversbronze.com

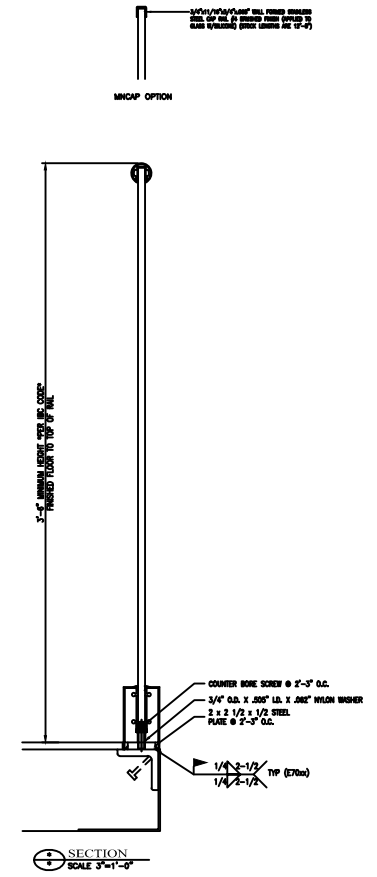
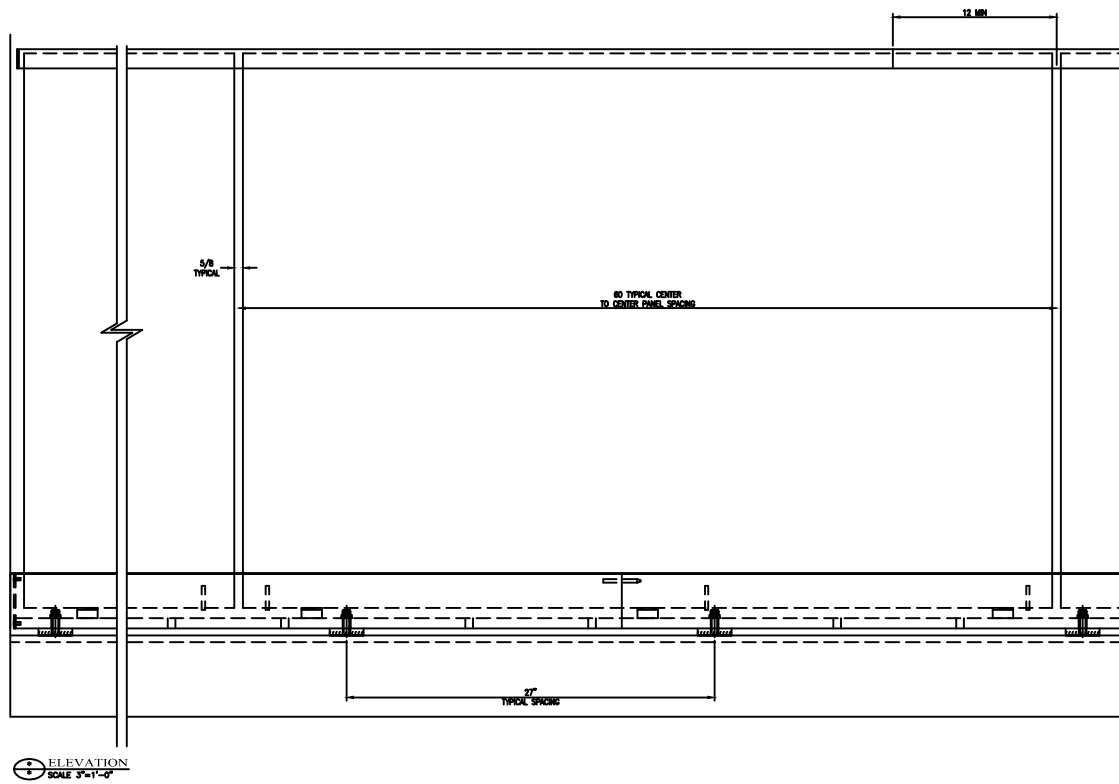

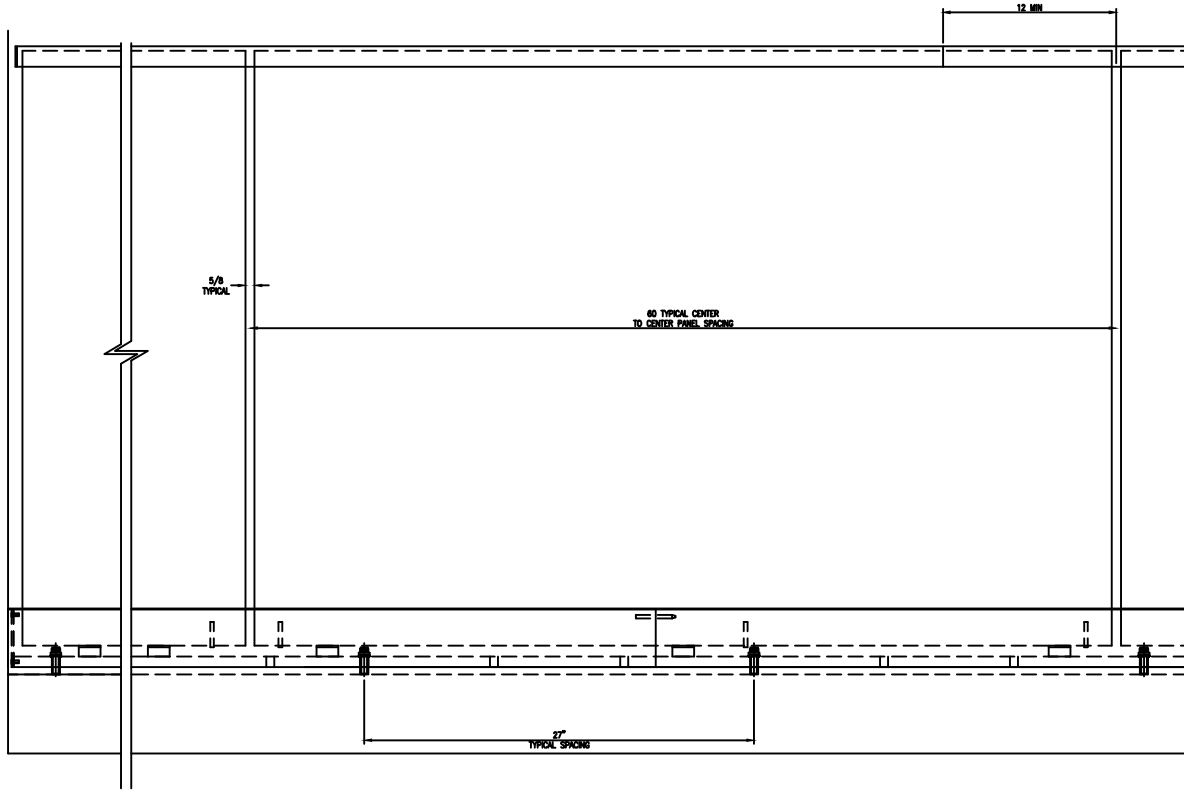

ELEVATION  
SCALE 3/4"=1'-0"

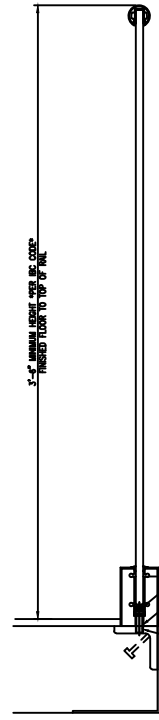
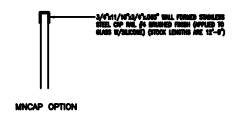

SECTION  
SCALE 3/4"=1'-0"

- COUNTER BORE SCREW @ 2'-0" O.C.
- 3/4" O.D. X .020" I.D. X .042" NYLON WASHER
- MUST FIELD DRILL AND TAP HOLES IN EMBED PLATE



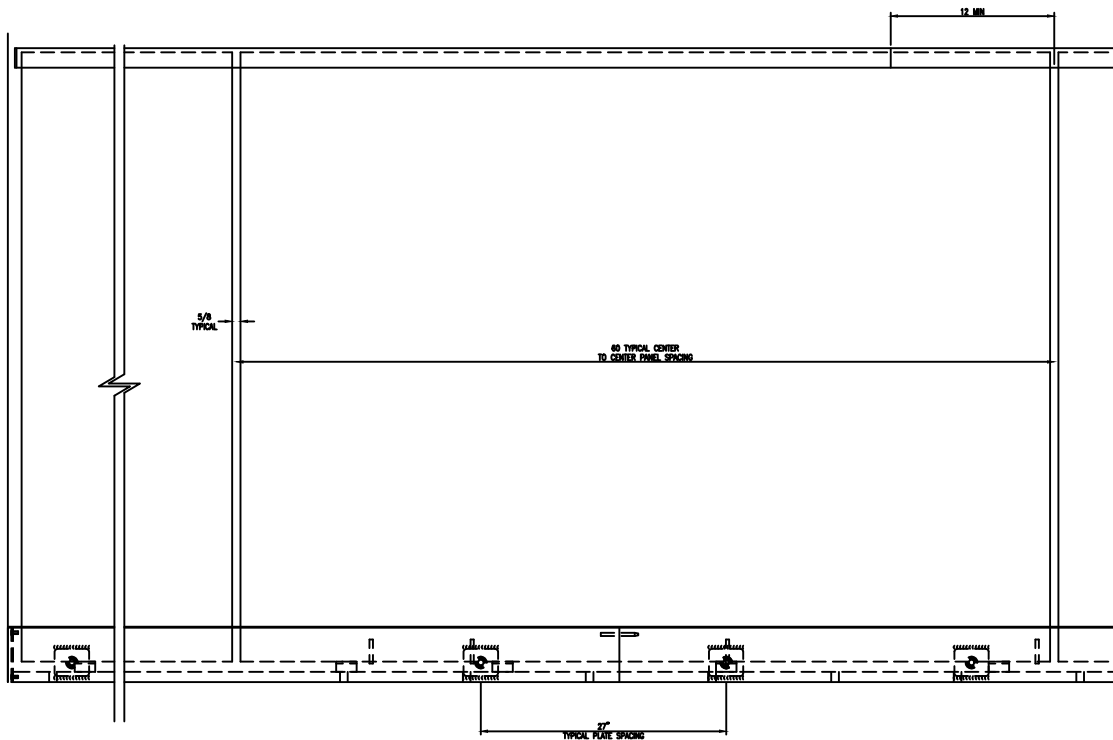

ELEVATION  
SCALE 3/4"=1'-0"

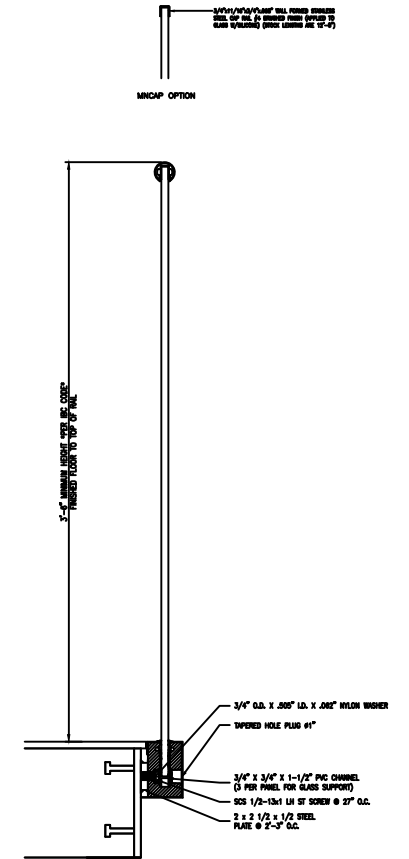

SECTION  
SCALE 3/4"=1'-0"

**LIVERS  
BRONZE**  
4645 LASH CREEK DRIVE, FORTLAUDERDALE, FL 34652  
 PHONE 352.342.2828 / FAX 352.342.2824  
 WWW.LIVERSBRONZE.COM  
 INFO@LIVERSBRONZE.COM

# RB1053-01 GLASS BRKT DETAIL

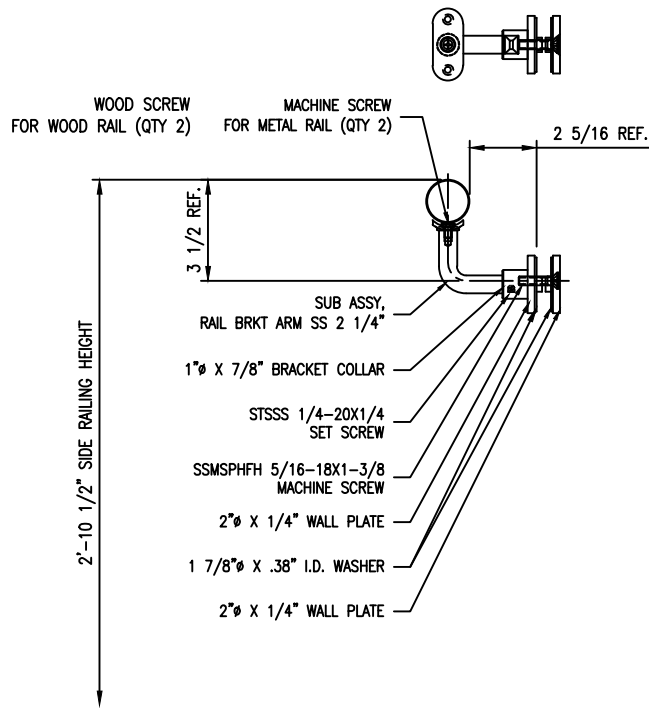

# RB2001-01 GLASS BRKT DETAIL

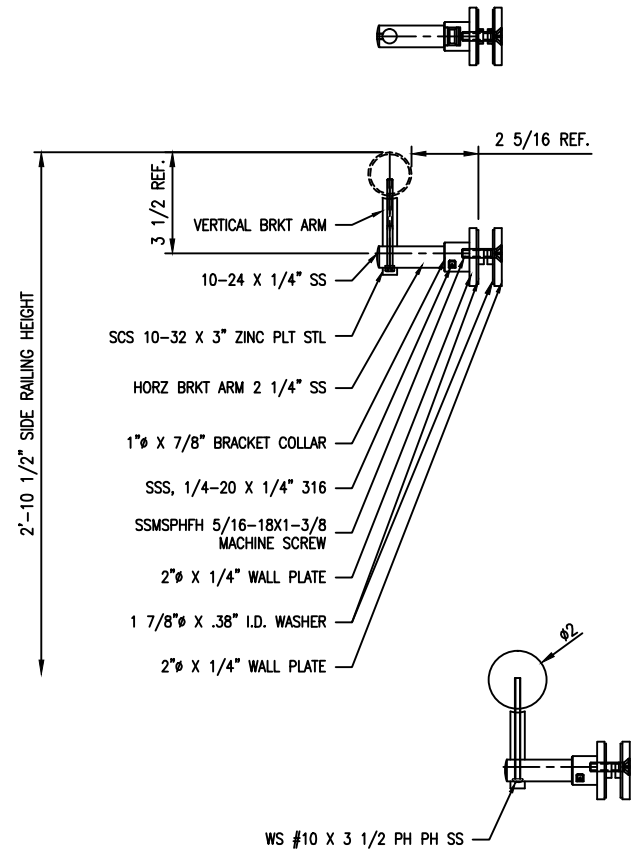

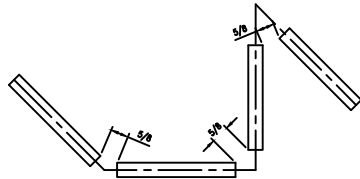

⊕ TYPICAL GLASS CORNERS DETAIL  
6" = 1'-0"

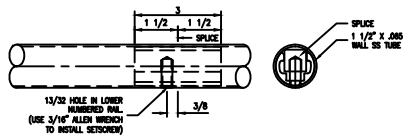

⊕ FACTORY CUT SPLICE  
6" = 1'-0"

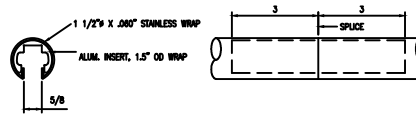

⊕ SPLICE DETAIL - 1 1/2" Ø STRAIGHT  
SCALE: 6" = 1"

**MATERIAL DESIGN STRENGTHS**

GLASS FULLY TEMPERED - PULNINGTON DATA A55-129 - 24,000PSI TYPICAL MEAN MOR

SOCKET CAP SCREW, STAINLESS - ASTM F837 - 80KSI TENSILE (MIN)

FLAT HEAD CAP SCREW, STAINLESS - ASTM F879 - 80KSI TENSILE (MIN)

HEX HEAD CAP SCREW, STAINLESS - ASTM F593 - 100KSI TENSILE (MIN)

BUTTON HEAD CAP SCREW, STAINLESS - ASTM F879 - 80KSI TENSILE (MIN)

BUTTON CAP SCREW, STAINLESS, 30316 BITHREAD - 100KSI TENSILE (MIN)

FLANGE 12-POINT SCREW, ALLOY STEEL - F4-115 - 170KSI TENSILE (MIN)

SELF-DRILLING TAPPING SCREW, STAINLESS - SAE J78 - 100KSI TENSILE (MIN)

BWR STAINLESS - 30KSI - YIELD (MIN)

BWR 1018 CF - ASTM A108 - 54KSI - YIELD

BWR ALUMINUM 6061-T6 & T6511 - 30KSI - YIELD (MIN)

BWR BR C205 - 20KSI - YIELD (MIN)

PIPE STAINLESS - ASTM A312 - 30KSI - YIELD (MIN)

PIPE WELDED STEEL - ASTM A53 Gr. B - 35KSI - YIELD (MIN)

PIPE SIZE TUBE, STEEL, ERW - A500 Gr. C - 48KSI YIELD (MIN)

PIPE ALUMINUM 6061-T6 - 30KSI - YIELD (MIN)

PIPE BR C230 - 18KSI - YIELD (MIN)

TUBE 304 STAINLESS - ASTM A240 - 30KSI YIELD (MIN)

TUBE CUSTOM STAINLESS, 1-1/2 DIAMETER X .065 WALL - 44KSI YIELD (MIN)

TUBE 1024 STEEL - ASTM A519 - 47KSI YIELD (MIN)

TUBE STEEL ERW - A500 Gr. B - A513 T1A2 - 44KSI YIELD (MIN)

TUBE ALUMINUM 6061-T6 - 35KSI YIELD (MIN)

LIVERS BRONZE CO. RECOMMENDS THRENO LOCKER 262, (DHW0023) TO SECURE ALL MECHANICAL CONNECTIONS